

DRAKE MODEL

**2-C**

RECEIVER



# TABLE OF CONTENTS

<u>Section</u>		<u>Page</u>
I	INSTALLATION -----	1
	1.1 Unpacking-----	1
	1.2 Mounting and Cabling -----	1
	1.3 Muting -----	1
	1.4 Anti-Vox and Sidetone -----	1
II	OPERATION -----	3
	2.1 Single Sideband Reception-----	3
	2.2 CW Reception -----	3
	2.3 AM Reception-----	4
	2.4 Accessory Frequency Coverage -----	4
III	PRINCIPLES OF OPERATION -----	8
	3.1 Block Diagram -----	8
	3.2 R.F. Circuits -----	8
	3.3 I.F. Circuits -----	9
	3.4 A.F. Circuits -----	9
	3.5 AVC System-----	10
	3.6 S-Meter-----	11
	3.7 Power Supply-----	11
IV	SPECIFICATIONS -----	12
	4.1 2-C Receiver-----	12
	4.2 Frequency Coverage -----	12
	4.3 Specifications -----	12
	4.4 Tubes and Semi-Conductors-----	14
V	SERVICE INSTRUCTIONS -----	15
	5.1 General -----	15
	5.2 Removal of Radio from Cabinet -----	15
	5.3 Trouble Shooting -----	15
	5.4 Alignment -----	18
VI	ACCESSORIES -----	22
	6.1 2-AC Crystal Calibrator-----	22
	6.2 2-CQ Speaker/Q-Multiplier and Notch Filter -----	22
	6.3 2-NB Noise Blanker -----	25
FIG.	1-1 Viewing Angle Options -----	2
	1-2 2-C Receiver and DRAKE 2-NT Transmitter -----	2
	1-3 2-C Receiver, T-4X Transmitter and AC-4/MS-4 Station -----	2
	2-1 Crystal Frequency Chart -----	6
	2-2 Preselector Chart -----	7
	3-1 2-C Receiver Block Diagram -----	8
	3-2 2-C Receiver Selectivity Curves -----	10
	5-1 Voltage Chart -----	16
	5-2 Resistance Chart -----	17
	5-3 Signal Tracing Chart -----	17
	5-4 Bottom View-----	21

SECTION I  
INSTALLATION

1.1 UNPACKING

Carefully remove the 2-C from the packing carton and examine it carefully for signs of shipping damage. If the receiver has been damaged in shipment, notify the delivering carrier at once, stating the full extent of damage. Save the packing material for later use for re-shipment or storage.

1.2 MOUNTING AND CABLING

The 2-C location is not critical. However, care should be taken to insure adequate air circulation around the receiver.

1.3 MUTING

The mute jack on the rear of the 2-C is connected so that when the Function switch is in EXT-MUTE, N.B. or CAL position, the receiver will operate only when the inner-conductor of this jack is shorted to chassis, and will mute when open with respect to chassis. The inner-conductor of a shielded cable must, therefore, be connected to a relay contact in the transmitter or antenna relay which is normally open when transmitting and grounded when receiving. If external muting is not desired, a shorting plug (furnished with 2-C) must be inserted in the mute jack to operate in N.B. and CAL positions.

1.4 ANTI-VOX AND SIDETONE

A sidetone jack is provided in the rear of the chassis for connection to the 2-NT Transmitter for monitoring the CW. This connection is shown in Fig. 1-2.

The cabling of the 2-C and T-4X shown in Fig. 1-3 provides sidetone operation for CW, spotting capabilities for putting both units on the same frequency and anti-vox input for the T-4X.

Anti-vox operation may be obtained with the 2-C and the DRAKE TR-4 Transceiver by connecting the speaker jack of the 2-C and TR-4 to a common speaker voice coil. Other transmitters having voice control capabilities may be operated with the 2-C by proper transformer matching between the ANTI-VOX input terminal of the transmitter and 2-C speaker output.

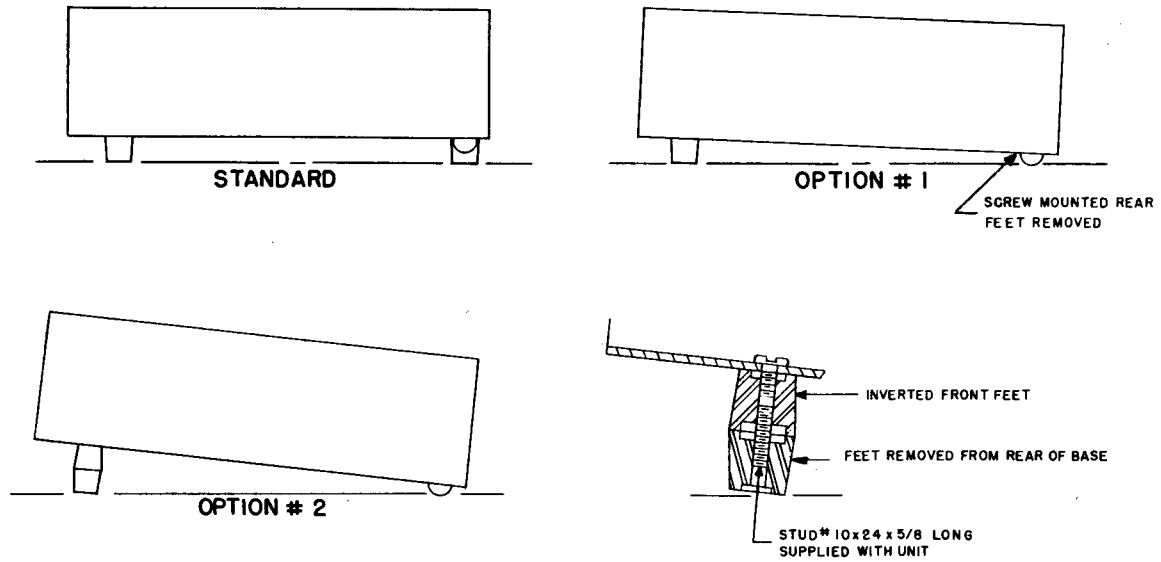

FIG. 1-1 VIEWING ANGLE OPTIONS

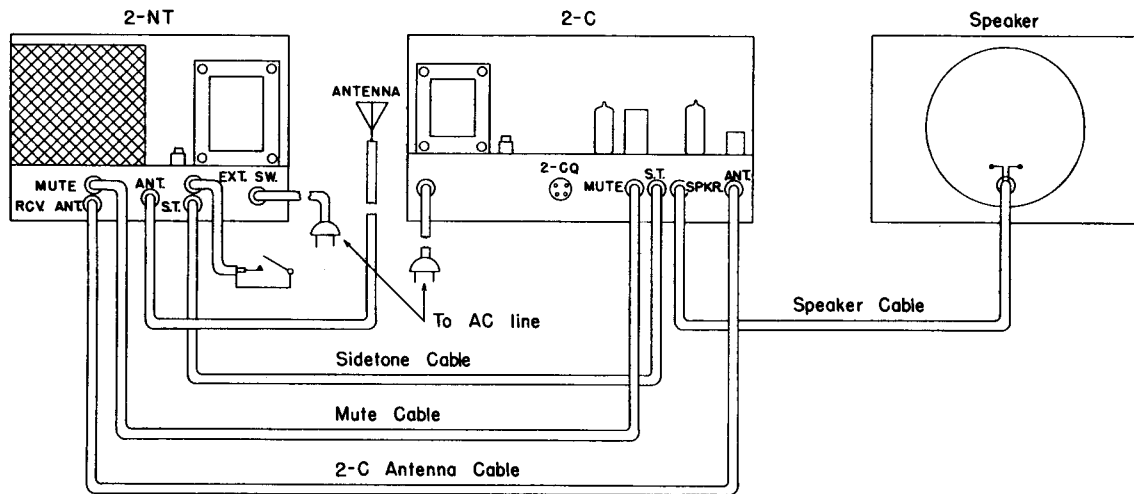

FIG. 1-2 2-C RECEIVER AND DRAKE 2-NT TRANSMITTER

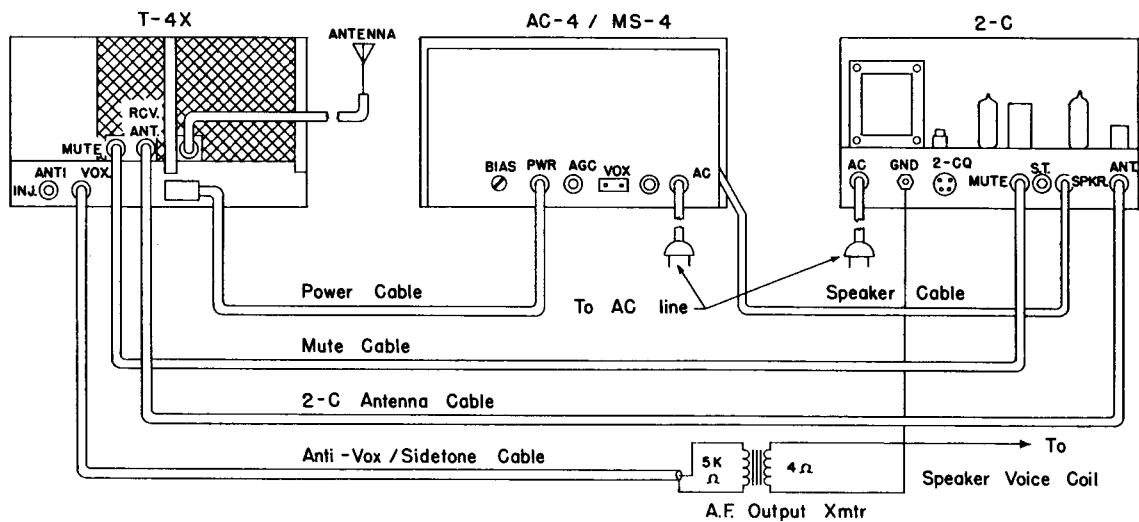

FIG. 1-3 2-C RECEIVER, T-4X TRANSMITTER AND AC-4/MS-4 STATION

SECTION II  
OPERATION

2.1 SINGLE SIDEBAND RECEPTION

<u>CONTROL</u>	<u>SETTING</u>
A. Function Switch	On (EXT MUTE if using external muting)
B. Band Switch	To desired band
C. Preselector	To desired band
D. Norm-Aux Switch	Norm. (AUX for accessory bands, see paragraph 2.4)
E. RF Gain	Fully clockwise
F. AF Gain	To desired audio level
G. AVC	Slow
H. Mode Switch	To desired sideband (LSB or USB)
I. Selectivity Switch	To 2.4 position
J. Tune in desired signal with Main Tuning control and tune preselector for maximum signal or S-meter reading.	
K. To read frequency, add the dial setting to the <u>BAND SWITCH</u> setting. The main dial is calibrated in 10 KHz*divisions. The vernier dial divisions are approximately 1 KHz. Frequencies in the 80 meter band and 10 meter band are marked in red on the dial.	

2.2 CW RECEPTION

- A. Set the controls as in paragraph 2.1, steps A through F.
- B. Set SELECTIVITY switch to 2.4 (.4 position for crowded band conditions).

\* This instruction book uses the new standard frequency designation.  
1 Hz = 1 C/S, 1 KHz = 1 KC/S. 1 MHz = 1 MC/S.

- C. To copy CW with AVC, set AVC to SLOW position. If AVC is not desired put AVC in OFF position, turn AF GAIN fully clockwise and control the output volume with the RF GAIN control.
- D. Tune Main tuning control for desired signal (keeping pre-selector tuned for maximum S-meter reading) CW may be tuned in either USB or LSB position. At times under crowded band conditions one sideband reception may be better copy than the other. The frequency of the received signal can be read by zero beating the signal. Due to the sharp selectivity of the .4 position this should be done in the 2.4 position or 4.8 position of the Selectivity switch.

### 2.3 AM RECEPTION

- A. Set controls as in paragraph 2.1, steps A through F.
- B. Set MODE switch to AM.
- C. Set SELECTIVITY switch to 4.8 position.
- D. Set AVC switch to SLOW.
- E. Tune in signal with main dial as described previously.

### 2.4 ACCESSORY FREQUENCY COVERAGE

In addition to reception of 80, 40, 20, 15 and the 28.5 - 29.0 portion of 10 meters, the 2-C can be used for reception of any frequency between 3.0 and 30 MHz. Position the slide switch located on the left hand side of the chassis to AUX position and insert the appropriate crystal in the AUX XTAL socket for desired frequency coverage as shown in Fig. 2-1. Position the slide switch in NORM position for coverage of 80, 40, 20, 15 and 28.5 - 29.0 portion of 10 meters. Unlock switch by loosening screw and rotating locking lug.

To determine the correct crystal to be used for a desired band, add 4 MHz to the lowest desired frequency. For operation on the 28.5 band, 4 MHz must be subtracted from the highest desired frequency to obtain the correct crystal frequency.

XTAL = Lowest desired frequency plus 4 MHz (all bands except 28.5)

XTAL = Highest desired frequency minus 4 MHz (28.5 band).

The chart on page 6 shows the crystals required and the BAND switch setting to obtain reception of any frequency between 3.0 and 30.0 MHz.

The crystal oscillator is designed for operation with series resonant crystals. Parallel resonant mode crystals will operate, however the frequency of oscillation may be in error by a few KHz. Calibration of the dial with a calibrated signal such as provided by the 2-AC Calibrator will compensate for any frequency error caused by the parallel mode crystals.

In order for a desired band to be received, the BAND switch must be tuned to a position which will allow the PRESELECTOR to tune the desired range. Recommended ranges are as follows:

<u>BAND</u>	<u>PRESELECTOR TUNING RANGE (MHz)</u>
3.5	3.0 to 4.5
7.0	4.5 to 10.0
14.0	10.0 to 16.5
21.0	16.5 to 24.0
28.5	24.0 to 30.0

The chart shown in Fig. 2-2 shows the coverage of the PRESELECTOR for each of the auxiliary bands. Solid lines shown the preferred coverage for each band while the dashed lines show limits of possible coverage.

The crystals furnished in the 2-C for coverage of the 40 and 20 meter ham bands can also be used for additional coverage as shown.

The 11 MHz crystal used on 40 will also cover 14.5 to 15 MHz as indicated by the Preselector chart on Page 7 and the equation shown at the top of Page 5.  $15.0 - 4 = 11$  MHz crystal.

The 18 MHz crystal used on 20 meters can also be used to cover 21.5 to 22 MHz.

Use the red numbers on the dial for coverage of these two extra bands.

FREQ. RANGE MHz	CRYSTAL MHz	BAND MHz	PRE-SEL SETTING	FREQ. RANGE MHz	CRYSTAL MHz	BAND MHz	PRE-SEL SETTING
3.0 - 3.5	7.0	3.5	0 - 3	16.5 - 17.0	20.5	21.0	7.0
3.5 - 4.0	None	3.5	3 - 6	17.0 - 17.5	21.0	21.0	7.2
4.0 - 4.5	8.0	3.5	6 - 10	17.5 - 18.0	21.5	21.0	7.3
4.5 - 5.0	8.5	7.0	1.5 - 2.5	18.0 - 18.5	22.0	21.0	7.5
5.0 - 5.5	9.0	7.0	3.0	18.5 - 19.0	22.5	21.0	7.6
5.5 - 6.0	9.5	7.0	3.5	19.0 - 19.5	23.0	21.0	7.8
6.0 - 6.5	10.0	7.0	4.5	19.5 - 20.0	23.5	21.0	7.9
6.5 - 7.0	10.5	7.0	5.0	20.0 - 20.5	24.0	21.0	8.1
7.0 - 7.5	11.0 *	7.0	5.2	20.5 - 21.0	24.5	21.0	8.2
7.5 - 8.0	11.5	7.0	5.7	21.0 - 21.5	25.0 *	21.0	8.3
8.0 - 8.5	12.0	7.0	6.0	21.5 - 22.0	25.5	21.0	8.5
8.5 - 9.0	12.5	7.0	6.4	22.0 - 22.5	26.0	21.0	8.7
9.0 - 9.5	13.0	7.0	6.7	22.5 - 23.0	26.5	21.0	8.9
9.5 - 10.0	13.5	7.0	7.0	23.0 - 23.5	27.0	21.0	9.0
10.0 - 10.5	14.0	14.0	5.0	23.5 - 24.0	27.5	21.0	9.2
10.5 - 11.0	14.5	14.0	5.2	24.0 - 24.5	20.5	28.5 **	8.0
11.0 - 11.5	15.0	14.0	5.5	24.5 - 25.0	21.0	28.5	8.1
11.5 - 12.0	15.5	14.0	5.8	25.0 - 25.5	21.5	28.5	8.3
12.0 - 12.5	16.0	14.0	6.1	25.5 - 26.0	22.0	28.5	8.4
12.5 - 13.0	16.5	14.0	6.3	26.0 - 26.5	22.5	28.5	8.5
13.0 - 13.5	17.0	14.0	6.6	26.5 - 27.0	23.0	28.5	8.7
13.5 - 14.0	17.5	14.0	6.8	27.0 - 27.5	23.5	28.5	8.9
14.0 - 14.5	18.0 *	14.0	7.0	27.5 - 28.0	24.0	28.5	9.0
14.5 - 15.0	18.5	14.0	7.2	28.0 - 28.5	24.5	28.5	9.1
15.0 - 15.5	19.0	14.0	7.4	28.5 - 29.0	25.0 *	28.5	9.3
15.5 - 16.0	19.5	14.0	7.6	29.0 - 29.5	25.5	28.5	9.6
16.0 - 16.5	20.0	14.0	7.8	29.5 - 30.0	26.0	28.5	9.9

\* Supplied with 2-C Receiver

\*\* 28.5 bands tuned using red numbers on dial

FIG. 2-1 CRYSTAL FREQUENCY CHART



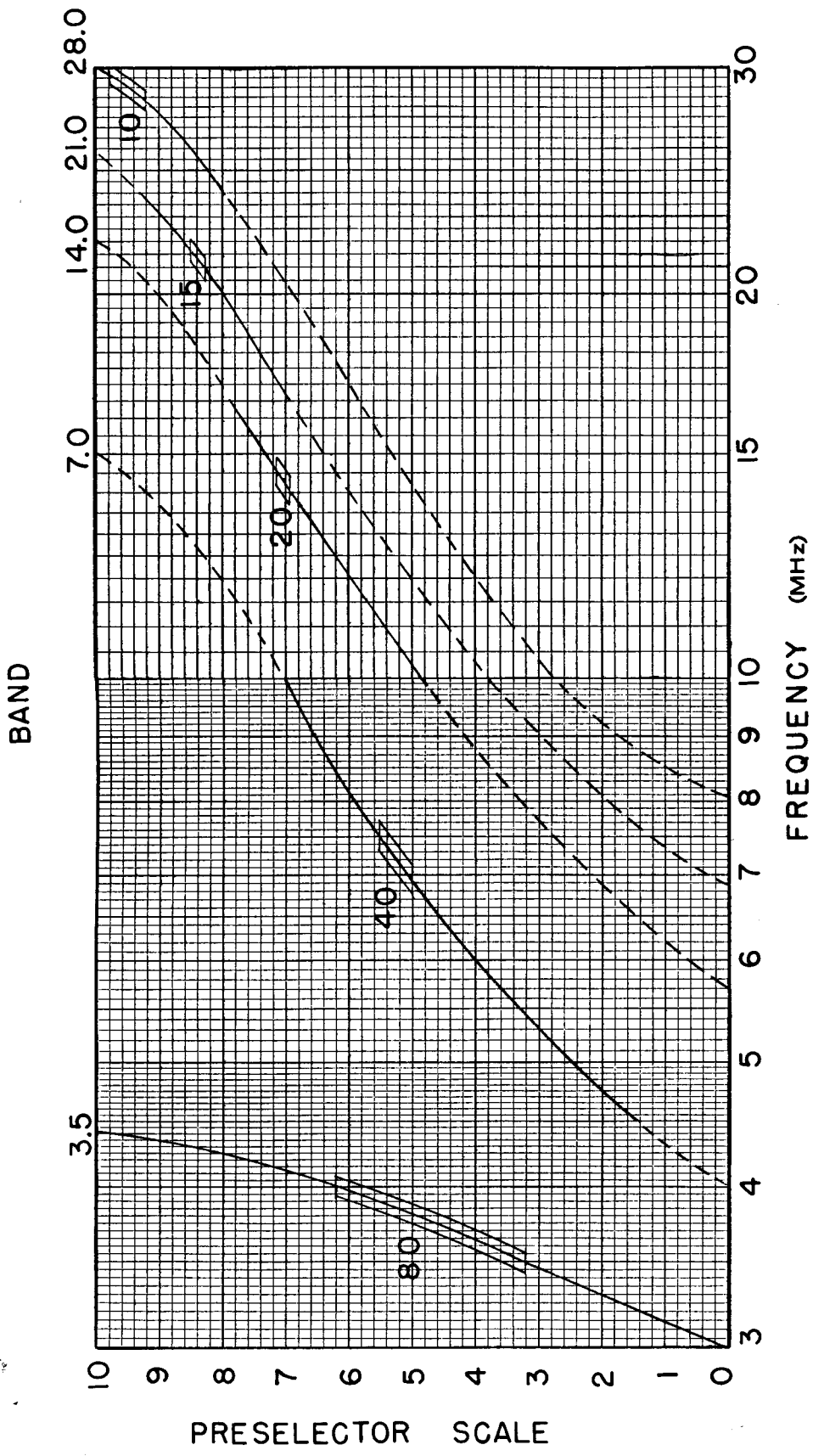

NOTE: SOLID LINE INDICATES RECOMMENDED RANGE FOR EACH BAND

FIG. 2-2 PRESELECTOR CHART

## SECTION III

### PRINCIPLES OF OPERATION

#### 3.1 BLOCK DIAGRAM

Fig. 3-1 is a block diagram of the 2-C Receiver. The 2-C is a triple-conversion receiver with a crystal controlled high frequency oscillator, a highly stable variable oscillator tuning the same range on all bands, and a steep-sided L-C filter in the 50 KHz I.F. providing selectivity.

The receiver provides front panel control of a wide variety of functions such as band width, AVC time constant, type of detector used, noise blanker and calibrator functions using the 2-NB and 2-AC accessory noise blanker and calibrator.

#### 3.2 R.F. CIRCUITS

A high gain, semi-remote cutoff pentode (12BZ6) exhibiting low inter-modulation and excellent control characteristics is used as the RF amplifier.

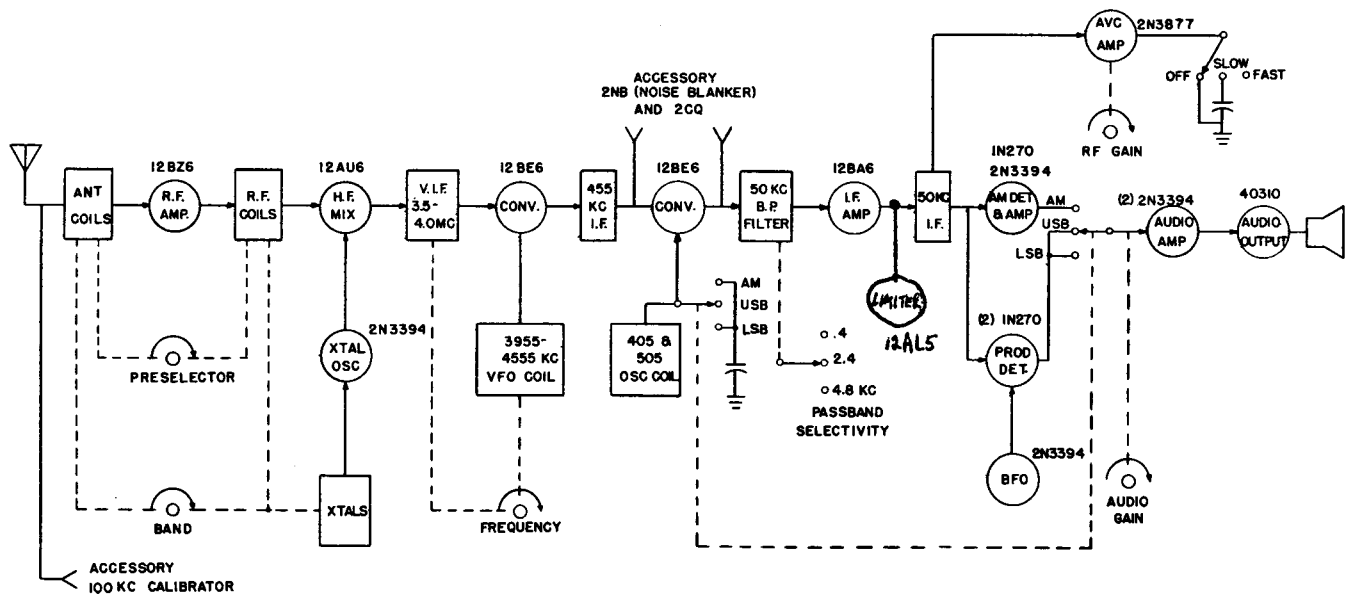

FIG 3-1 2-C RECEIVER BLOCK DIAGRAM

The antenna terminal (50 to 75 ohms unbalanced input impedance) is transformer coupled to the RF amplifier input. The RF input and output coils are tuned to resonance on the forty meter bands by the ganged capacitors tuned by the PRESELECTOR control. The preselector tunes the other bands by band switching capacitance or inductance across the RF input and output coils.

A 12AU6 pentode is used to mix the incoming signal (supplied from the RF amplifier) with the selected frequency from the crystal oscillator, producing the variable IF frequency (3500 to 4000 KHz).

### 3.3 I. F. CIRCUITS

A 12BE6 pentode is used as the second mixer and variable frequency oscillator with a tuning range of 3955 to 4555 KHz. A ganged capacitor is used to tune both the variable IF and the VFO. On all bands the VFO tunes the same range thereby giving uniform tuning rate throughout and contributing to the excellent stability of the receiver.

The variable IF signal mixing with the VFO signal produces a 455 KHz IF signal which is applied to the third converter (12BE6). The third converter is also used as an oscillator, fixed tuned to either 405 KHz or 505 KHz which mixes with the 455 KHz IF to produce an IF signal of 50 KHz. Upper and lower sideband operation is determined by selecting either the 505 or 405 KHz oscillator.

I. F. selectivity is determined by the pass band filter which consists of four tuned circuits of very high Q, tuned to the same frequency. The selectivity switch, switches coupling and shunt capacitance in each tuned circuit to provide three steep sided selectivity curves as shown in Fig. 3-2.

The output of the side band filter is amplified by the I. F. amplifier tube (12BA6) and is coupled to the AVC amplifier and the detector circuitry through the 50 KHz I. F. transformer.

### 3.4 A. F. CIRCUITS

A solid state product detector exhibiting excellent low intermodulation and harmonic distortion properties combine the incoming 50 KHz signal with the extremely stable BFO signal to produce the audio output signal for SSB, CW and RTTY communications.

AM detection is provided by a diode detector.

The output and bias of the AM detector and the BFO product detector is switched by the MODE switch thus applying the audio output signal to the A. F. volume control.

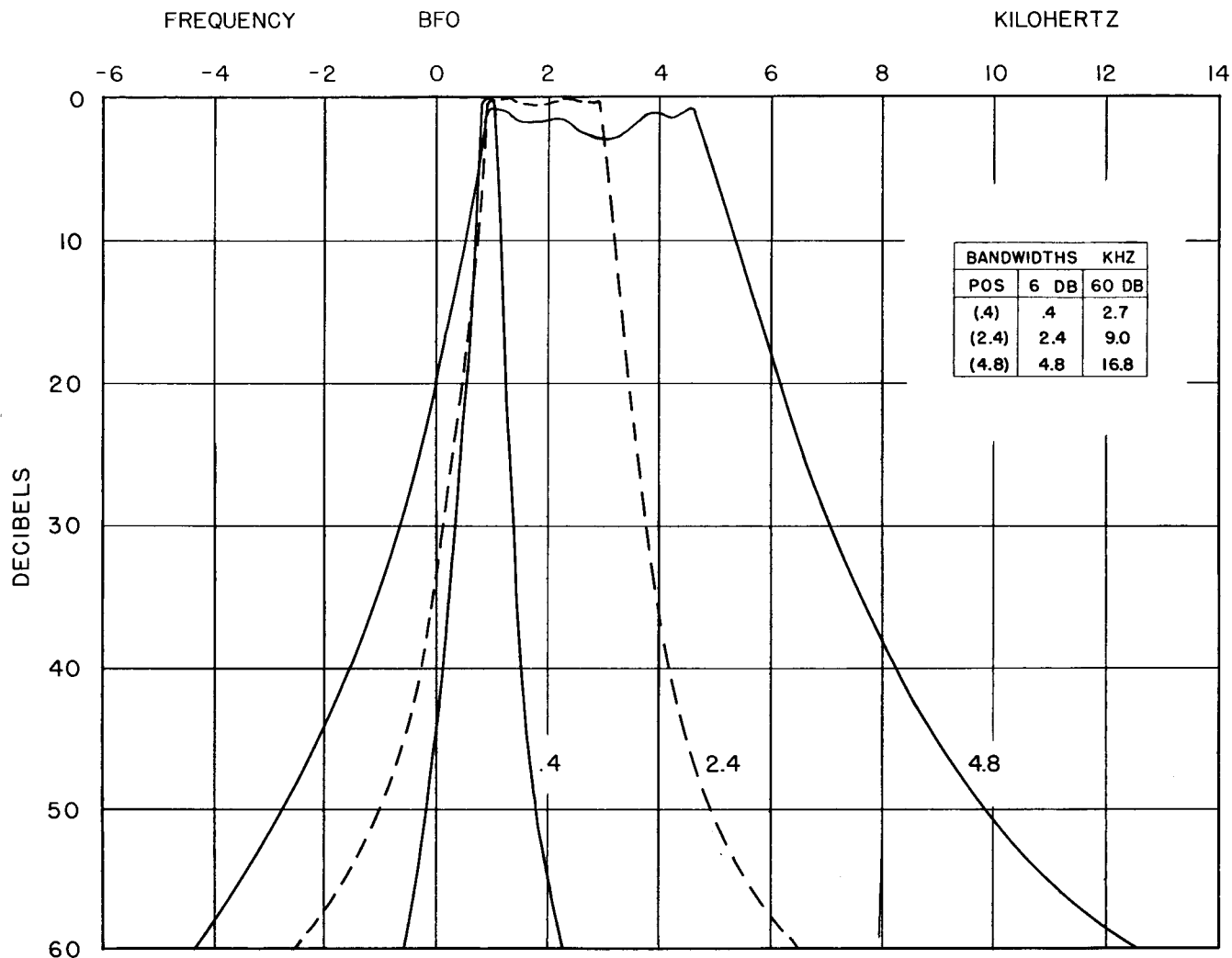

FIG 3-2 2-C SELECTIVITY CURVES

The audio signal at the A.F. volume control is applied to the solid state audio amplifier circuitry which employs feedback principles to reduce distortion and provide desirable audio response of the amplifier.

The audio output stage will deliver 1.8 watts of audio to a 4 ohm speaker which is matched by the output transformer.

A headphone jack on the side of the chassis disables the speaker terminals for private listening.

### 3.5 AVC SYSTEM

The solid state AVC amplifier Q5 is biased past cut-off to provide AVC delay. The AVC is inoperative on very weak signals thereby allowing full gain operation of the receiver. When the RF signal increases above that required to overcome the AVC threshold, the AVC amplifier provides a negative voltage proportional to the incoming RF signal. This negative AVC voltage is applied to the control grids of V1, V4 and V5 thereby limiting their gain and providing a more constant output.

The AVC switch, switches resistance-capacitance networks in the AVC circuitry providing slow or fast AVC action. The AVC attack time is less than 100 microseconds and either a slow release of about .75 seconds or fast release of about .025 seconds can be selected. Switching the AVC to off prevents AVC voltage from being developed and the receiver operates at full gain on all signals.

Rotating the RF gain counter-clockwise applies increasingly more negative bias to the AVC controlled tubes thus limiting their gain.

When the mute terminal is opened from ground, the bias voltage rises to -30 volts, thus cutting off the AVC controlled tubes.

### 3.6 S-METER

The S-meter operates in a bridge circuit with the plates of tubes V1 and V5 in one leg and V2, V3 and V4 in the other leg. AVC voltage applied to the grids of V1, V4 and V5 causes the tubes to draw less current, thereby unbalancing the bridge and causing the S-meter to read up scale.

### 3.7 POWER SUPPLY

Two full wave power supplies employing diode rectifiers are used to provide a high DC voltage for the tube circuits and a low DC voltage for the transistor circuitry.

A negative bias supply using a single diode provides -60 volts to the AVC system for minimum bias, muting and control of RF gain.

Dial Calibration ----- Main dial calibrated 0 to 500 KHz in 10 KHz divisions.

Vernier dial calibrated in approximately 1 KHz divisions.

Both main dial and vernier are adjustable for calibration purposes.

AVC --- Amplified delayed AVC having slow (.75 sec.) or fast (.025 sec.) discharge and less than 100 microsecond charge. AVC can also be switched off. Less than 6 DB audio change for 100 DB RF input change.

Audio Output ----- 1.8 watts with less than 5% distortion and .75 watts at AVC threshold.

Hum Level----- Greater than 60 dB below rated output.

Audio Output Impedance ----- 4 ohms

Antenna Input ----- Nominal 52 ohms.

Spurious Responses--- Image rejection greater than 60 DB; IF rejection greater than 60 DB on ham bands; internal spurious signals within ham bands less than the equivalent 1 uv signal on the antenna.

Power Consumption ----- 30 watts, 120 VAC, 50/60 Hz

Size ----- 11-5/16 inches wide,  
6-9/32 inches high,  
9-3/32 inches deep.

Weight----- 13-1/2 pounds

#### 4.4 TUBES AND SEMI-CONDUCTORS

<u>TUBES</u>	<u>FUNCTION</u>
12BZ6	R.F. Amplifier
12AU6	1st Mixer
12BE6	VFO Controlled 2nd Mixer
12BE6	3rd Mixer
12BA6	50 KHz IF Amplifier
12AL5	I.F. NOISE LIMITER

<u>SEMI-CONDUCTORS</u>	<u>FUNCTION</u>
2N3394	Crystal Oscillator
2N3877	AGC Amplifier
2N3394	50 KHz Oscillator
(2) 1N270	Product Detector
1N270 and 2N3394	AM Detector and Amplifier
(2) 2N3394	Audio Amplifier
40310 (RCA)	Audio Output
(2) 1N3194	Hi voltage Rectifier
(2) 1N3194	Lo voltage Rectifier
1N3194	Bias Rectifier

## SECTION V

### SERVICE INSTRUCTIONS

The 2-C Receiver will be checked and factory aligned for a nominal fee of Ten (\$10.00) Dollars plus transportation charges if the radio has not been tampered with. If repairs are necessary, an additional charge will be made. Radios that have been tampered with will be repaired on a time and material basis.

#### 5.1 GENERAL

Included in this section are signal tracing procedures, alignment procedures and voltage/resistance measurements.

In general, most troubles encountered in radio equipment of good design is due to tube failure rather than component failure. The 2-C has been designed so that its tubes may be replaced without need for realignment. The best test of tubes is direct substitution in the equipment rather than reliance on a tube checker.

#### 5.2 REMOVAL OF RADIO FROM CABINET

- A. Remove the two top screws on each side of the 2-C.
- B. Remove top cover by first pulling up on the rear and then on the front of the cabinet.
- C. Remove the two bottom screws on each side of the radio.
- D. Lift the 2-C chassis out of the bottom cover.

#### 5.3 TROUBLE SHOOTING

Careful consideration has been given in the design of the 2-C to keep maintenance problems to a minimum. However, some problems may arise which cannot be cured by tube substitution. If this occurs, it is suggested that you either return the radio to your dealer, or write direct to the R. L. DRAKE COMPANY Service Department, describing your problem in detail. Include full information concerning external connections, control settings, tube substitutions, etc.

DO NOT RETURN EQUIPMENT TO FACTORY WITHOUT PRIOR AUTHORIZATION



The voltage and resistance charts of Fig. 5-1 and 5-2 should be valuable in isolating minor problems. However, no attempt should be made to service the receiver unless you are thoroughly familiar with electronic circuitry and servicing techniques.

Figure 5-3 lists significant test points useful in localizing a problem. All RF and IF measurements were made by connecting a vacuum-tube volt meter to the AVC line and increasing the signal generator signal applied to the indicated test point until the AVC voltage increased to -3 volts. The signal voltage values were taken from the signal generator output attenuator scale.

All values of signal voltages, resistance measurements and test point voltages are nominal and may vary widely without degrading performance.

SWITCH POSITIONS:

Band switch ----- 40 meters  
 Preselector ----- 40 meter position  
 Function switch----- On  
 RF Gain ----- Full clock-wise  
 AF Gain ----- At mid position  
 Mode switch ----- LSB  
 Band width ----- 2.4 position  
 AVC ----- Slow  
 Crystal slide switch ----- NORM

FIG. 5-1

VOLTAGE CHART

TUBE	TYPE	1	2	3	4	5	6	7
V1	12BZ6	-1.1	.6	0	12.6*	90	95	0
V2	12AU6	-.02	0	0	12.6*	100	95	1.5
V3	12BE6	- 4	0	0	12.6*	100	90	-2.5
V4	12BE6	- 7	0	0	12.6*	100	50	-1.2
V5	12BA6	-1.2	0	0	12.6*	100	90	0
Q7	40310	(case 12.5 v)						

\* AC voltage

FIG. 5-2

## RESISTANCE CHART

TUBE	TYPE	1	2	3	4	5	6	7
V1	12BZ6	4.4M	150	0	Fil	24K	20K	0
V2	12AU6	1M	0	0	Fil	20K	24K	470
V3	12BE6	170K	330	0	Fil	20K	21K	7K
V4	12BE6	160K	0	0	Fil	20K	26K	3.5M
V5	12BA6	4.6M	0	0	Fil	22K	20K	0

NOTE: All measurements were made with a 11 megohm VTVM and are with respect to chassis. Line voltage maintained at 120 volts for voltage measurements and DISCONNECTED FROM LINE for resistance measurements.

FIG. 5-3

## SIGNAL TRACING CHART

TEST POINT	FREQUENCY	VOLTAGE	AGC VOLTAGE
J1	7.3 MHz	20 microvolts	- 3 V
V1-P1	7.3 MHz	250 microvolts	- 3 V
V2-P1	3.7 MHz	100 microvolts	- 3 V
V2-P1	7.3 MHz	1 millivolt	- 3 V
V3-P7	455 KHz	1 millivolt	- 3 V
V3-P7	3.7 MHz	1 millivolt	- 3 V
V4-P7	51 KHz	10 millivolts	- 3 V
V4-P7	455 KHz	15 millivolts	- 3 V
V5-P1	51 KHz	25 millivolts	- 3 V

NOTE: Switch positions same as given for voltage and resistance measurements. Signal generator output is coupled to indicated test point through a .01 uf coupling capacitor.

## 5.4 ALIGNMENT

Alignment of the 2-C requires correct relationship between the various oscillators and should be done by competent service personnel with the necessary frequency determining equipment.

### A. 50 KHz OSCILLATOR (BFO)

Connect an accurate source of 50 KHz signal through a capacitor to Pin 1 of V-5. With the MODE switch in either LSB or USB adjust the slug in T11 for zero beat. If a 2-AC crystal calibrator accessory is available, the BFO may be tuned by connecting Pin 1 of V-5 to the antenna terminal through a .01 mfd coupling capacitor.

If a frequency meter or receiver is being used rather than a generator, it should be loosely coupled to the output terminals (1 or 2) of T11 and tuned to the lowest 100 KHz point to which it can be set accurately. With the MODE switch in either LSB or USB adjust the slug in T11 for zero beat of its harmonic on the indicating instrument. A re-check should be made at the next higher 100 KHz point on the instrument to be sure the correct harmonic was reached.

### B. 405/505 KHz OSCILLATOR

If a frequency meter or receiver is used, loosely couple to Pin 5 of V4. Switch the MODE switch to USB. Set the instrument to 1010 KHz and adjust the slug of T7 for zero beat. (Second harmonic of 505 KHz oscillator) Switch the MODE switch to LSB. Set the instrument to 810 KHz and adjust the trimmer capacitor C-54 for a zero beat.

If a signal generator is being used, feed a 455 KHz signal to Pin 7 of V4. This point is available through the 2-CQ socket J-2. Tune the slug of T7 for zero beat with the MODE switch in USB. Switch the MODE switch to LSB and adjust the trimmer capacitor C-54 for zero beat.

### C. 455 KHz I.F.

Tune in a signal from the antenna and tune both top and bottom slugs of T4 for maximum S-meter reading or maximum negative voltage measured with a VTVM on TP-1.

#### D. VFO ALIGNMENT

Connect to the ANT terminal a crystal calibrator or signal generator providing outputs at 3600 and 4000 KHz. Set band switch to 80 meters and preselector knob to 80. Tune in 3600 KHz signal and note dial error. Tune in 4000 KHz signal and again note dial error. If both errors are in the same direction, slide dial to reduce or compromise error. If error is too great for this minor adjustment, retune to 3600 KHz on the dial scale and adjust slug in T-3 for zero beat. Recheck at 4000 KHz. Adjust dial to compromise error. Repeat until desired accuracy is achieved.

While it should not be necessary, if the error in tracking the VFO from end to end appears too large to be corrected by the process outlined, changing the value of C-21 (which is selected in production to correct differences in minimum capacity) will correct the end to end error. Adding to this capacity will narrow the spread while reducing it will increase the spread. To repeat, this should only be tried if the condition cannot be corrected by the method suggested earlier.

#### E. VARIABLE I.F. ALIGNMENT

To adjust the Variable I.F. transformer set band switch to 80 meters and connect a generator or calibrator to the ANT terminal. Tune in the signal at 3800 KHz. Adjust T-3 for maximum S-meter reading.

#### F. PRESELECTOR ALIGNMENT

NOTE: Field alignment of the preselector should be avoided if possible. Extensive use of increment coil switching is made in the preselector and serious mis-alignment and tracking error on other bands may occur if the Antenna or RF coils are incorrectly adjusted. If a check on the center of each band shows that the noise with antenna disconnected can be peaked by the preselector tuning knob, further alignment is not warranted.

If front end alignment is deemed absolutely necessary, proceed as follows:

Set band switch to 40 meters. Feed into antenna a signal generator or crystal calibrator at 7200 KHz. Tune in signal and peak with preselector tuning control. This point should be at or very

near the 40 meter mark on the preselector dial. If not, check pointer to see if it is correctly oriented with the end of shaft rotation. Pointer should read 10 when it is at the clock-wise end of rotation. If this is correct, reset the preselector dial to the middle of the 40 meter area and carefully peak the bottom slugs of T1 and T2 for maximum S-meter reading. Move the band switch to the 80 meter band and the generator to 3800 KHz. Tune in signal and carefully peak with preselector. While rocking preselector dial peak C-1 for maximum S-meter reading.

Turn band selector switch to the 10 meter band. Set generator to 28.8 MHz. Tune in signal and tune preselector to the middle of the 10 meter area. Adjust the top slugs of T1 and T2 for maximum S-meter reading. All other bands are tuned by addition of increment coils to the variable inductances already adjusted; They should require no further alignment.

#### G. PASS BAND FILTER ALIGNMENT

Field alignment of the pass band filter should be avoided if possible. This assembly has been factory aligned and alignment should not be attempted unless absolutely necessary. If filter alignment is deemed necessary, proceed as follows.

Apply an accurate source of 50.80 KHz signal to Pin 7 of V4 (12BE6). Adjust the signal level to approximately 20 millivolts. Place the selectivity switch in the .4 position and tune the four slugs in the T6 coils of the pass band filter for maximum negative voltage on TP1. These four slugs may be tuned with a non-metallic alignment tool from the rear of the chassis.

#### H. BIAS AND S-METER ADJUSTMENT

Attach a VTVM to TP1 and with the Preselector detuned and the antenna disconnected, adjust the RCVR SENS control for -1.35 volts. Remove the VTVM and adjust the S-Meter Zero control, located on the back of the chassis, for a reading of S-1 on the S-meter.

Attach the VTVM to TP1 and turn the RF gain control counter-clockwise for -11 volts and adjust the S-Meter Sensitivity control for 40 DB over S9. Recheck the S-meter zero and sensitivity setting with the receiver upright and readjust if necessary.

NOTE: The AVC line is a very high impedance circuit and will be loaded with low impedance VTVM probes. Readings specified here are obtained using a 11 megohm probe with the AVC switch in the slow position.

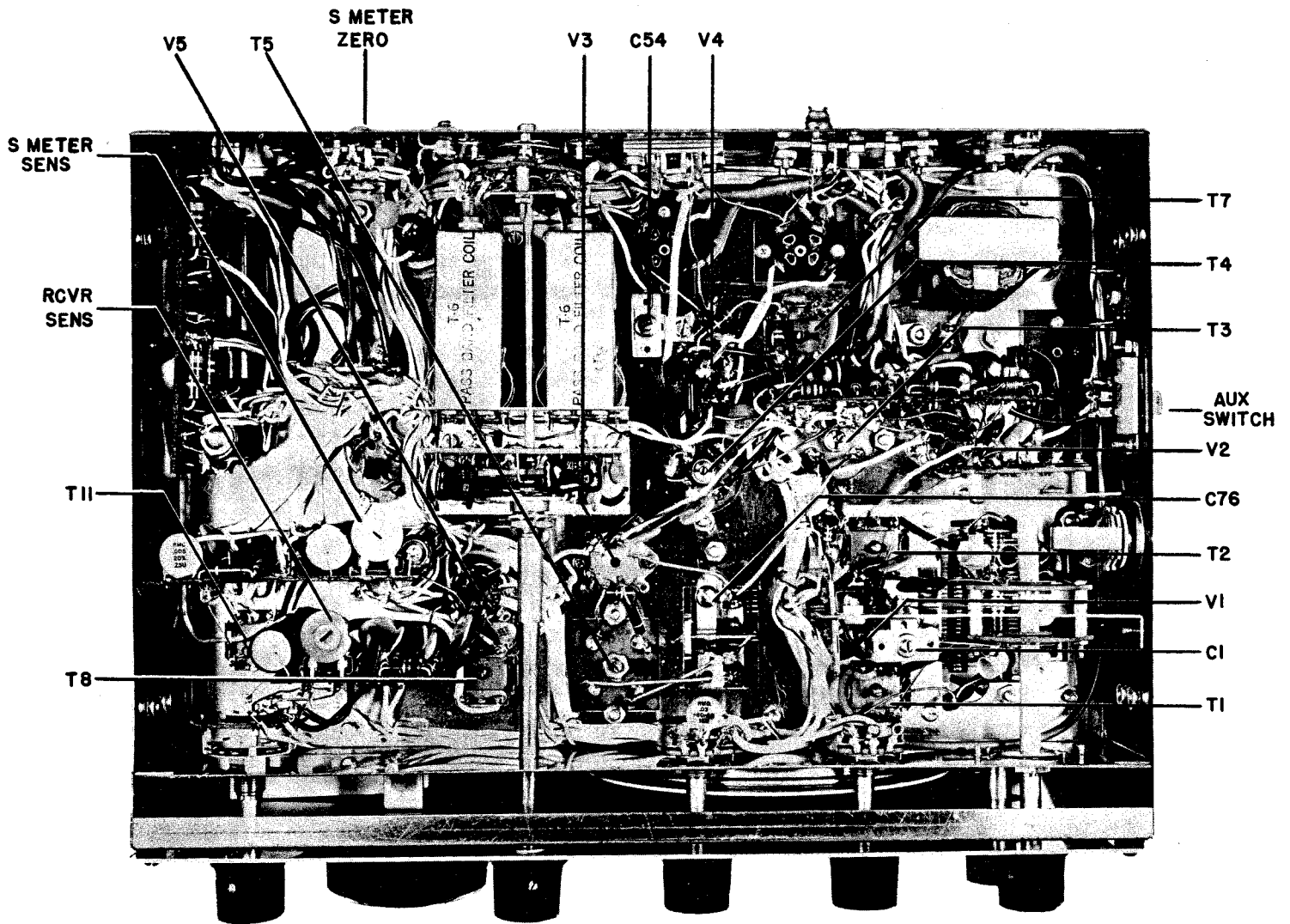

FIG. 5-4 BOTTOM VIEW

### 6.1 2-AC CRYSTAL CALIBRATOR

The 100 KHz Crystal Calibrator is an oscillator so designed that it will inject into the 2-C Receiver a harmonic every 100 KHz throughout the receiver's range. THIS CORRESPONDS TO THE NUMBERED DIAL DIVISIONS ON THE RECEIVER.

The calibrator is used by plugging it into the 2-AC socket on top of the receiver chassis, putting the FUNCTION switch in CAL position and tuning in the 100 KHz harmonic nearest the desired operating frequency to zero beat the receiver BFO. The sliding pointer on the dial is then moved to calibrate the receiver.

### 6.2 2-CQ SPEAKER/Q-MULTIPLIER AND NOTCH FILTER

The 2-CQ is a Q-multiplier and notch filter combination housed in a matching speaker cabinet for use with the 2-C Receiver for providing increased selectivity and notching out interfering heterodynes and other interfering signals.

A socket on the rear of the 2-C chassis is provided for use with the 2-CQ. Operating controls are mounted on the front of the 2-CQ for tuning the Q-Multiplier or notch filter.

#### Installation with Model 2-C Receiver

1. Plug Q-Multiplier cable into 2-CQ socket on rear of 2-C.
2. Connect speaker lead to jack on 2-C marked SPKR.
3. When the Q-Multiplier is not being used, the PEAK-NOTCH switch should be on NOTCH and the ON-OFF switch should be on OFF.

#### Operating Instructions

Finding the notch setting of the 2-CQ controls for the first time may present a problem. However, practicing with a strong steady carrier such as our 2-AC Crystal Calibrator should enable the operator to obtain good results if the following procedure is carried out.

1. With the 2-CQ switches in the OFF and NOTCH positions, tune in a crystal calibrator signal on the 2-C Receiver.
2. Set the Q-BALANCE control to about 12 o'clock and turn ON-OFF switch to ON.
3. Carefully tune the TUNING knob for a slight null in S-meter reading. It will probably be shallow and rather broad.

4. When the null is found, readjust the Q-BALANCE for further null. Alternately adjusting Q-BALANCE and TUNING controls should produce about 50 dB of attenuation. Leave Q-BALANCE control at this setting for all notching.

#### Notching out a Heterodyne on SSB or AM

1. With the Q-BALANCE control set as described above, turn ON-OFF switch to OFF.
2. Tune in the station you wish to hear in the normal manner as described in the 2-C manual.
3. When a heterodyne appears, turn the ON-OFF switch to ON and slowly turn TUNING knob to a position where the heterodyne is eliminated. NOTE: On AM a heterodyne is caused by a beat between desired carrier and an interfering carrier. Removal of either will stop the heterodyne but if you notch out the carrier of the desired signal, the audio will become greatly distorted.
4. If the interfering carrier drifts in frequency, follow it with the Q-Multiplier TUNING; i.e., you tune the receiver for the best signal and tune the Q-Multiplier to remove the interference.

Keep in mind that the Q-BALANCE control is a balancing device when the 2-CQ is used for notching and as such it has only one correct setting. Even a very slight movement of this control from its correct setting will result in a drastic reduction in attenuation.

#### Peaking a CW Signal

1. With the 2-CQ switches set for OFF and NOTCH, tune in a CW signal on the 2-C Receiver as described in the instruction book.
2. Now set the 2-CQ switches to ON and PEAK and tune the TUNING control to the signal by noting a marked increase in the S-meter reading.
3. Set the Q-BALANCE control for the desired sharpness of response. Adjusting the Q-BALANCE control clockwise to a point just short of where the unit breaks into oscillation will result in maximum selectivity for peaking purposes.

#### ALIGNMENT

To remove the 2-CQ from the cabinet, remove the 3 bottom screws. Pull the bottom of the unit to the rear until it is in a horizontal plane. Rotate the unit about 45° and pull straight back out of the case.

1. Plug the 2-CQ into the receiver.
2. Turn the receiver on and tune in a strong steady carrier or a signal such as the crystal calibrator, zero beating it against the BFO.
3. Make sure the 2-CQ is switched to OFF and NOTCH and adjust L2 of the 2-CQ to peak S-meter reading.
4. Switch the 2-CQ to ON and PEAK, turn the TUNING control until it points to the center of its scale, and tune the Q-BALANCE control anywhere below the point of oscillation.





### 6.3 2-NB NOISE BLANKER

Solid state circuitry is used exclusively in the 2-NB and provides true noise blanking by quieting the receiver during the interval of the noise pulse.

A portion of the 455 KHz signal is applied to the Noise Blanker where it is amplified to a level sufficient to operate a pulse detector and separation circuit. Noise pulses received at the antenna will cause the Noise Blanker circuitry to produce a low impedance load to the signal in the I.F. amplifier during the duration of the pulse thus quieting the receiver to the noise pulse.

The superior Noise Blanker operation is obtained by putting the noise blanker circuitry ahead of the high selectivity stages of the receiver thereby preventing ringing of the hi-Q circuits by the noise pulses.

#### Operation

The Noise Blanker is an I.F. device which turns off the receiver I.F. amplifier during a noise pulse. It is effective on all modes of operation and greatly attenuates most impulse type noise. It will be noted that the noise blanker works best on noise pulses which are very short in duration and are separated widely in time (i.e. automobile ignition type noise). The closer the pulses are together, the less effective the noise blanker will be since the noise detector circuitry has more difficulty distinguishing the noise from the desired signal.

For normal operation under "no noise" conditions, the FUNCTION switch should be positioned in other than the NB position. The noise blanker functions only when the amplitude of the noise pulses exceed the amplitude of the signal. It will be noted that the S-meter will decrease when the noise blanker is switched on. This is due to the noise pulses causing AVC action when the blanker is off causing the S-meter to read high. When the noise blanker is switched on, the I.F. is turned off during the impulse period and the AVC is now activated by the signal rather than the noise pulse and the receiver gain increases. Due to the effect of AVC in giving constant audio output, the noise may not appear to decrease when the blanker is switched on. However, switching the blanker on increases the gain as described above and signals that were buried under the noise will now increase.

Very strong signals (30 or 35 dB over S9) will cause a slight distortion in the audio quality of the signal due to the dynamic range capability of the noise blanker circuitry. This should cause no detrimental effects since signals of this strength should far exceed noise conditions.

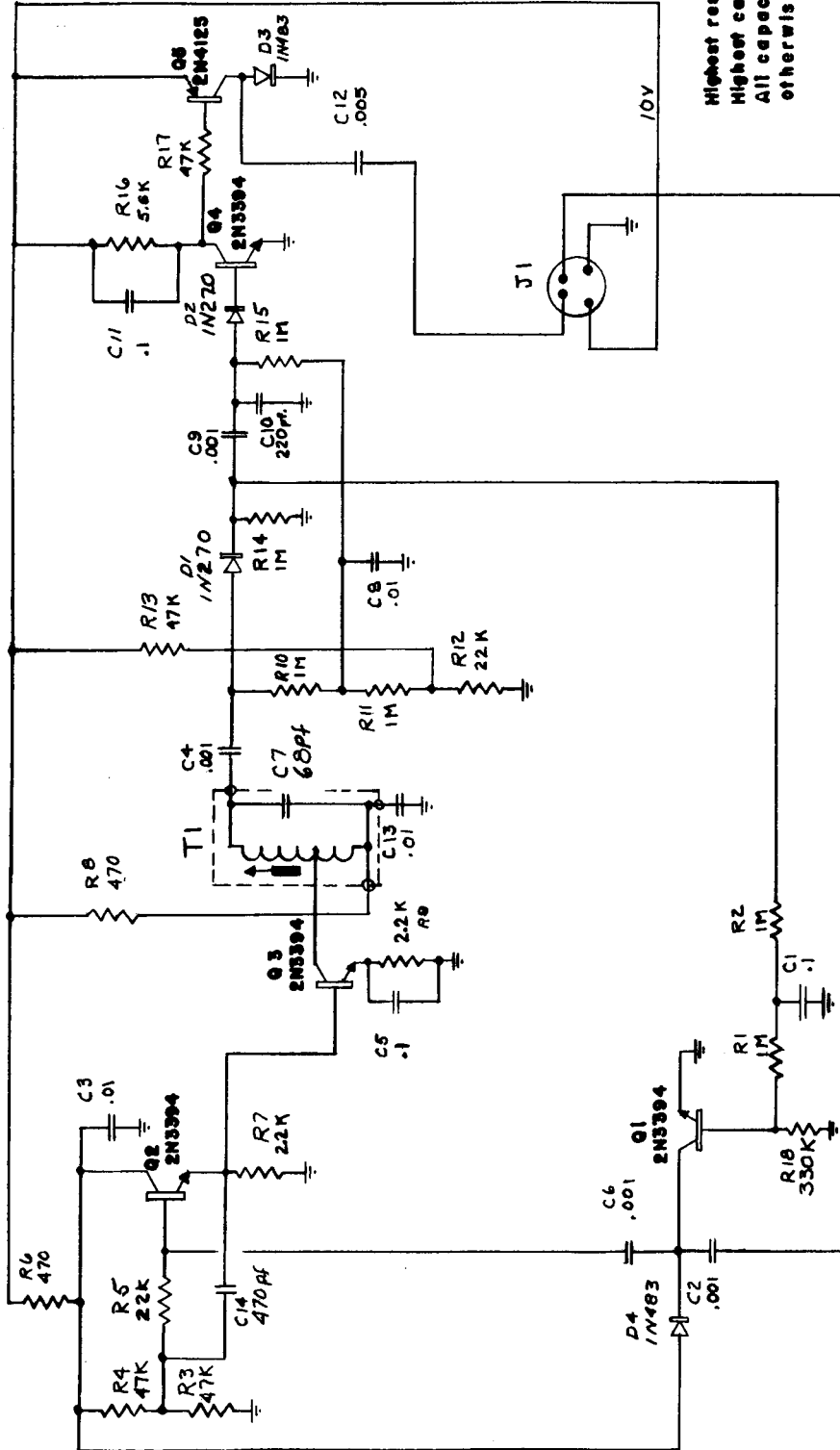

Highest resistor is R18  
 Highest capacitor is C14  
 All capacitors are in mfd. unless  
 otherwise noted.

2 - NB NOISE BLANKER

2-C SPARE PARTS LIST

February 1, 1970

Prices subject to change  
without notice

QTY	SYMBOL	ITEM	PRICE EACH
1	-----	Cabinet, Top & Bottom with feet	\$12.50
1	-----	Capacitor, Electrolytic, 50-20-10 @150V	2.00
1	C53	Capacitor, Electrolytic, 8 mfd @150V	.70
2	-----	Capacitor, Electrolytic, 1000 mfd @ 15 V	1.75
1	C45	Capacitor, Electrolytic, 10 @ 150 V	.70
2	-----	Capacitor, Trimmer, 2-15 pf	.76
1	C4-C9	Capacitor, Variable, pre-selector	3.00
1	C19-20	Capacitor, Variable, tuning, frequency	3.00
1	-----	Carton, shipping	2.50
--	-----	Controls, Var. Resistor, P.C. types specify	.40
1	R68	Controls, Var. Resistor, RF gain, 10K	.75
1	R43	Controls, Var. Resistor, AF gain, 3K	.70
1	R2B	Control, Var. Resistor, S-meter zero, 5K	.60
4	L1 thru L4	Coil, increment, specify	.20
1	-----	Fuse MDL - 3/4	.22
1	-----	Knob, large, tuning	.80
7	-----	Knob, small, control specify	.30
1	-----	Meter, "S"	4.80
--	-----	Plug, accessory, 4 Pin	.25
1	-----	Passband Tuner Assembly (Write Factory)	
1	-----	Panel, 2-C	6.00
--		Resistors: All 1 watt types	.20
		All 2 watt types	.25
		All 5-7 watt types	.30
1	S1	Switch, Band	2.50
1	S2	Switch, AVC	1.20
1	S3	Switch, Function	1.41
1	S5	Switch, Mode	1.75
1	-----	Switch, Slide, Auxiliary Crystal	.20
7	T1 thru T5 T7 & T11	Transformer, RF	4.00
1	T12	Transformer, Audio	2.25
1	T10	Transformer, Power	7.50
6	Q1 thru Q6	Transistor, 2N3394	.30
1	Q7	Transistor 40310	1.25
		Tubes:	
	V1	12BZ6	1.20
	V2	12AU6	1.45
	V3, 4	12BE6	1.28
	V5	12BA6	1.05
--	-----	Shaft, main tuning with mounting bracket	1.25
		Miscellaneous:	
--	-----	Cable, 2-C to 2-NT	1.05

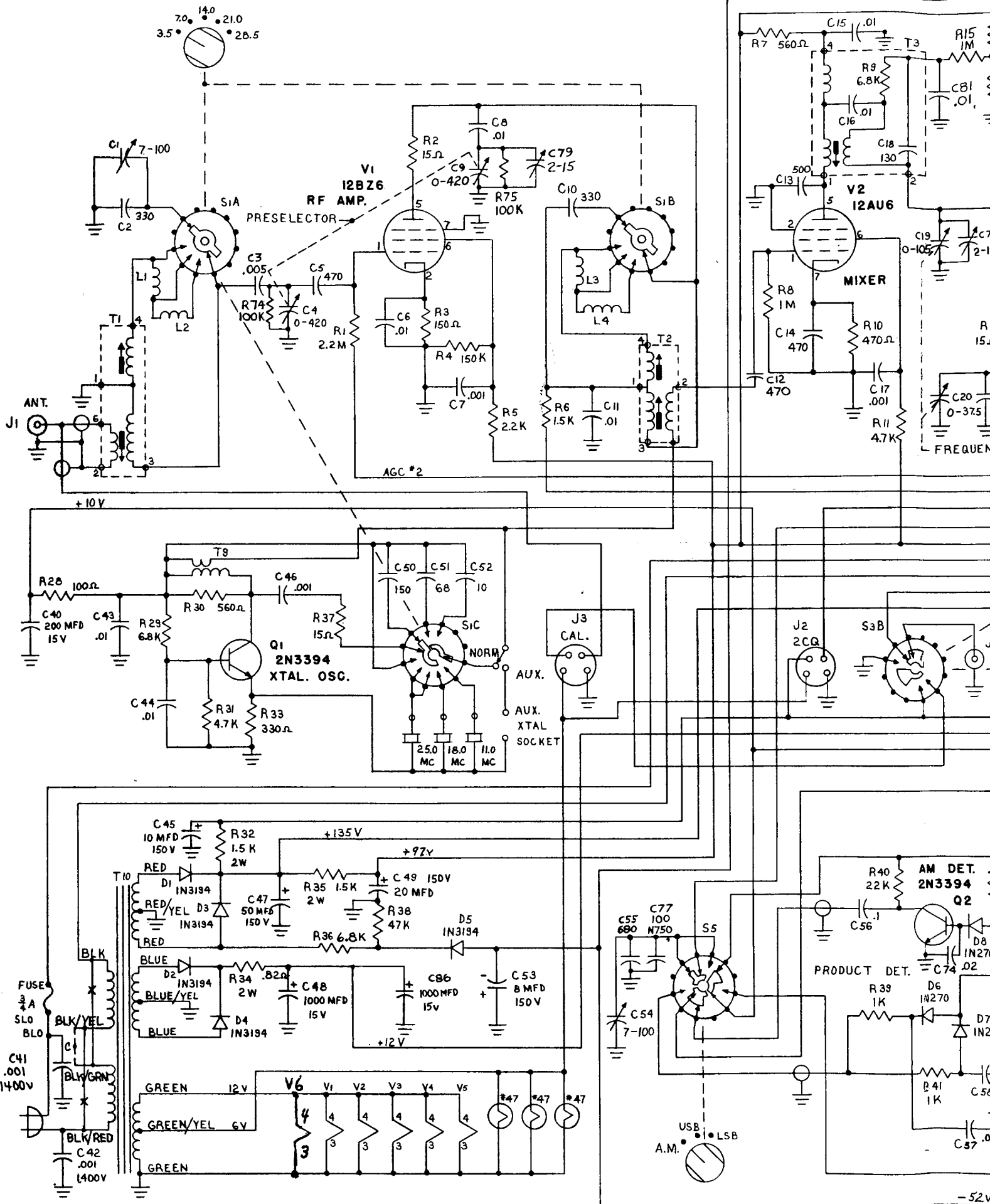

NOTES: Capacitors marked 1.0 to 3000 are in pf and capacitors from .001 to .47 are in uf unless otherwise noted. \* Indicates value selected in production.

SCHMATIC DIAGRAM MODEL

815671000

#2

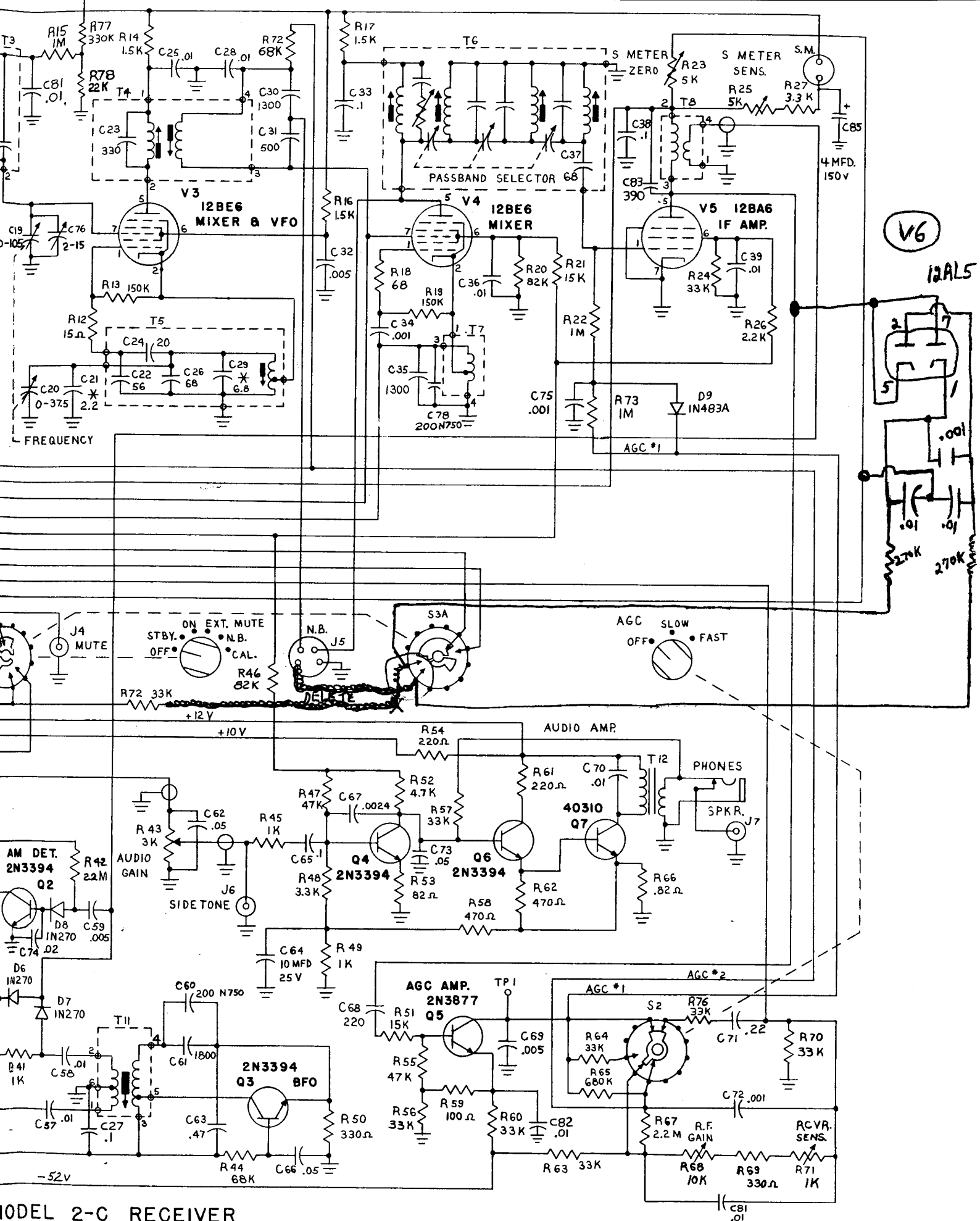

MODEL 2-C RECEIVER

1000 #2924

Resistors are 1/2 watt 10% unless otherwise noted.  
 All switches viewed from front in counterclockwise position.  
 Highest resistor R78 Highest capacitor C86

# INSTRUCTIONS FOR DRAKE MODEL 2-C Q SPEAKER/Q-MULTIPLIER

## Installation with Model 2-C Receiver

1. Plug Q-Multiplier cable into 2-CQ socket on rear of 2-C.
2. Connect speaker lead to jack on 2-C marked SPKR.
3. When the Q-Multiplier is not being used, the PEAK-NOTCH switch should be on NOTCH and the ON-OFF switch should be on OFF.

## Operating Instructions

Finding the notch setting of the 2-CQ controls for the first time may present a problem. However, practicing with a strong steady carrier such as our 2-AC Crystal Calibrator should enable the operator to obtain good results if the following procedure is carried out.

1. With the 2-CQ switches in the OFF and NOTCH positions, tune in a crystal calibrator signal on the 2-C Receiver.
2. Set the Q-BALANCE control to about 12 o'clock and turn ON-OFF switch to ON.
3. Carefully tune the TUNING knob for a slight null in S-meter reading. It will probably be shallow and rather broad.
4. When the null is found, readjust the Q-BALANCE for further null. Alternately adjusting Q-BALANCE and TUNING controls should produce about 50 dB of attenuation. Leave Q-BALANCE control at this setting for all notching.

## Notching out a Heterodyne on SSB or AM

1. With the Q-BALANCE control set as described above, turn ON-OFF switch to OFF.
2. Tune in the station you wish to hear in the normal manner as described in the 2-C manual.
3. When a heterodyne appears, turn the ON-OFF switch to ON and slowly turn TUNING knob to a position where the heterodyne is eliminated. NOTE: On AM a heterodyne is caused by a beat between desired carrier and an interfering carrier. Removal of either will stop the heterodyne but if you notch out the carrier of the desired signal, the audio will become greatly distorted.
4. If the interfering carrier drifts in frequency, follow it with the Q-Multiplier TUNING; i.e., you tune the receiver for the best signal and tune the Q-Multiplier to remove the interference.

Keep in mind that the Q-BALANCE control is a balancing device when the 2-CQ is used for notching and as such it has only one correct setting. Even a very slight movement of this control from its correct setting will result in a drastic reduction in attenuation.

## Peaking a CW Signal

1. With the 2-CQ switches set for OFF and NOTCH, tune in a CW signal on the 2-C Receiver as described in the instruction book.
2. Now set the 2-CQ switches to ON and PEAK and tune the TUNING control to the signal by noting a marked increase in the S-meter reading.
3. Set the Q-BALANCE control for the desired sharpness of response. Adjusting the Q-BALANCE control clockwise to a point just short of where the unit breaks into oscillation will result in maximum selectivity for peaking purposes.

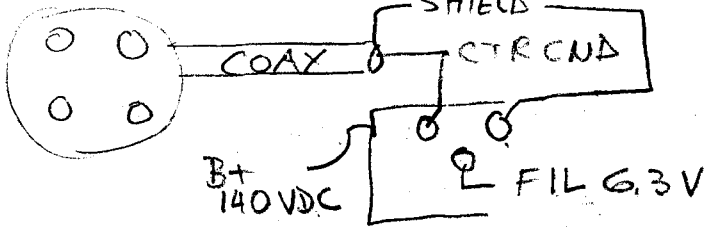

**ALIGNMENT**

To remove the 2-CQ from the cabinet, remove the 3 bottom screws. Pull the bottom of the unit to the rear until it is in a horizontal plane. Rotate the unit about 45° and pull straight back out of the case.

1. Plug the 2-CQ into the receiver.
2. Turn the receiver on and tune in a strong steady carrier or a signal such as the crystal calibrator, zero beating it against the BFO.
3. Make sure the 2-CQ is switched to OFF and NOTCH and adjust L2 of the 2-CQ to peak S-meter reading.
4. Switch the 2-CQ to ON and PEAK, turn the TUNING control until it points to the center of its scale, and tune the Q-BALANCE control anywhere below the point of oscillation.
5. Then adjust L1 (the coil in the aluminum can) for peak S-meter reading.

This completes the alignment procedure. Return the 2-CQ to its case by reversing the removal procedure.

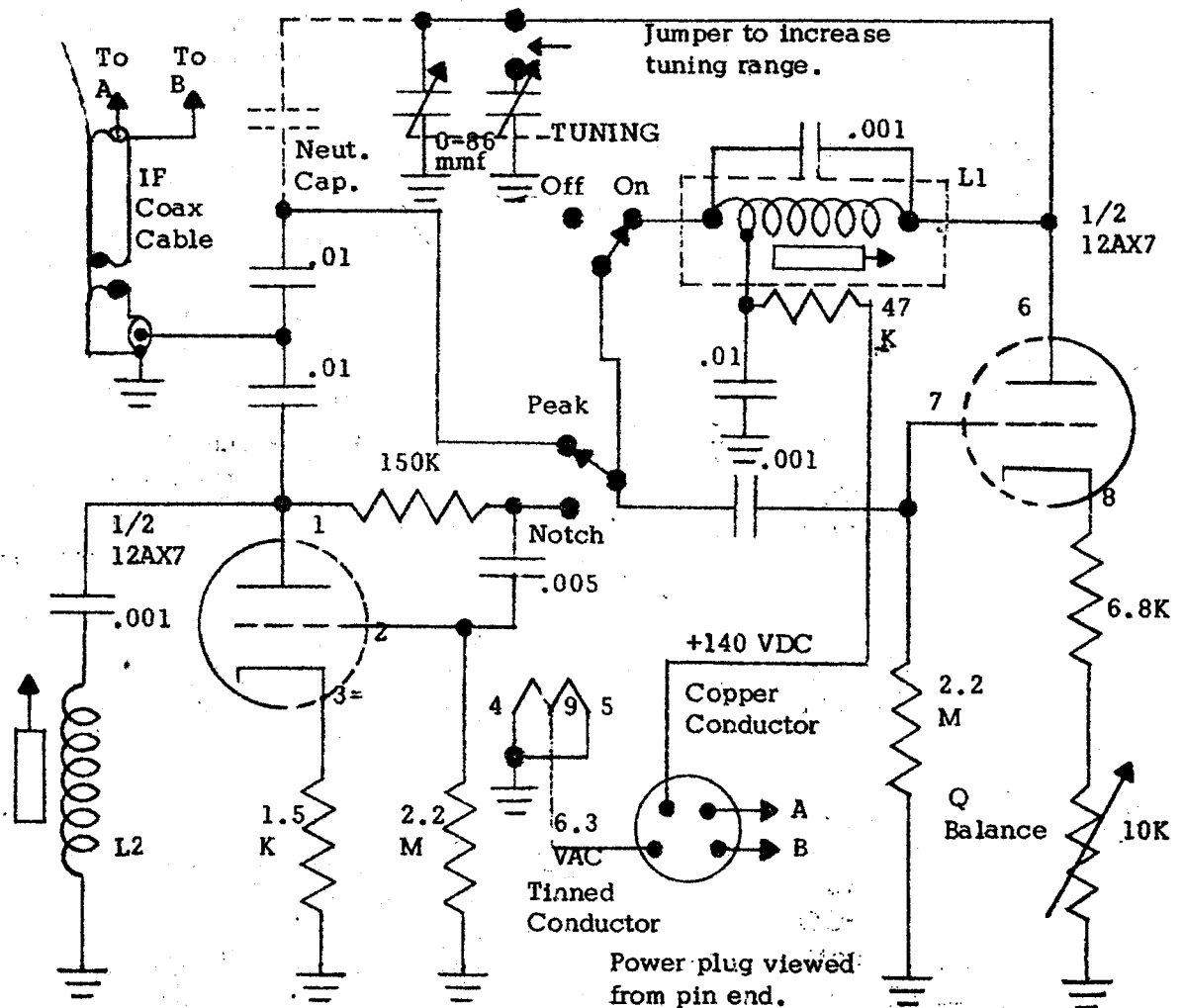

**SCHEMATIC DIAGRAM - 2-CQ**